

PULSEO
GENERATION

HA20 LE PRO



ECO-FRIENDLY

- > Electric drive and operations
- > Clean and silent operation designed for use in even the most sensitive work areas

VERSATILE. WORKS ANYWHERE, ANYTIME

- > Non-marking tyres for indoor use (optional)
- > 4 wheel drive for rough terrain use
- > Work quietly without work site disruptions

OPTIMAL PRODUCTIVITY

- > 360° continuous rotation turret (PRO model)
- > Quick, proportional and simultaneous movements
- > Platform load capacity 250 kg
- > Dual load capacity, up to 350 kg (optional)

EXTEND DUTY CYCLE, INCREASE PRODUCTIVITY

- > Power through a full work shift
- > Built-in multi-voltage charger
- > Low fuel consumption range extending engine

HA20 LE / LE PRO

ELECTRIC ROUGH TERRAIN ARTICULATING BOOMS

TECHNICAL DATA

HA20 LE PRO 4WD-4WS

Working height	20.76 m
Platform height	18.76 m
Horizontal outreach	11.91 m
Up and over clearance	8.52 m
Lift capacity	250 kg (option 350 kg)
F X G Platform size	1.83 x 0.80 m
A Length	8.54 m
B Width	2.41 m
C Height - stowed	2.5 m
H Length - transport	6.19 m
Height - transport	3 m
Platform rotation	180° (+90°/-90°)
Turret rotation	360° continuous
Tailswing	0.41 m
D Wheelbase	2.5 m
E Ground clearance	0.46 m
Tilt	4°
Drive speed	0.7 - 5 km/h
Gradeability	45 %
Tyres - solid rough terrain	1025 x 365 mm
Turning radius - outside	3.7 m
Weight	9 785 kg
Batteries	12 x 6V - 435 Ah (C20)
Range extender	Kubota Tier 4 Final - 18.5 kW

STANDARD EQUIPMENT

- > Haulotte Activ'Lighting System
- > Haulotte Activ'Shield Bar 2.0 (LE PRO model)
- > Haulotte Activ'Screen
- > Universal telematics plug
- > 72V battery pack (435 Ah)
- > Centralized battery watering system
- > Battery charge indicator at upper and lower control boxes
- > Multi-voltage charger (110-230V) and integrated range extender (18.5 kW)
- > Haulotte Activ'Energy Management : smart battery management system
- > 4 wheel drive: brushless AC motors at each wheel
- > 4 wheel steer (LE PRO), 2 wheel steer (LE)
- > Front oscillating axle
- > Smooth and proportional movements
- > 250 kg load capacity
- > Upper control box cover
- > Tool tray
- > Modular platform 1.83 x 0.80 m with drop bar entry gate
- > AC power to platform (110 / 230V)
- > Swing out engine tray
- > Sound and light alarm for tilt and load
- > Safe to use in winds up to 45 km/h (28 mph)
- > Travel alarm
- > Rotating beacon

OPTIONS AND ACCESSORIES

- > Non-marking tires
- > Dual load capacity 250 / 350 kg
- > Haulotte Activ'Shield Bar 2.0 (LE model)
- > 3.5 kW Power inverter
- > Large platform 2.44 x 0.91 m
- > Side swing door entry gate
- > Pipe rack kit
- > Glazier kit
- > Power to platform 110/230 V (female plug in the basket)
- > Biodegradable hydraulic oil
- > Cold weather kit
- > Anti overspeed kit
- > Air-line to platform
- > Flashing light

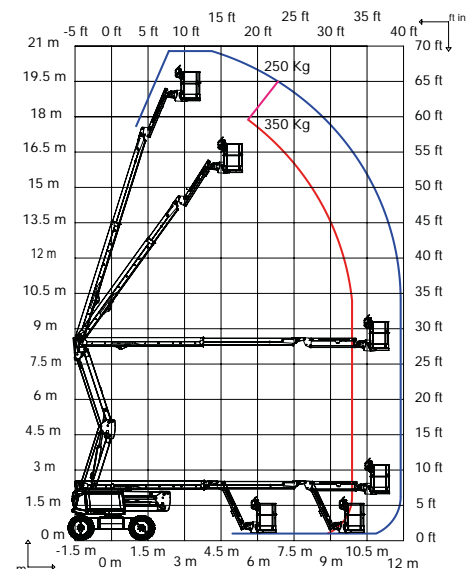
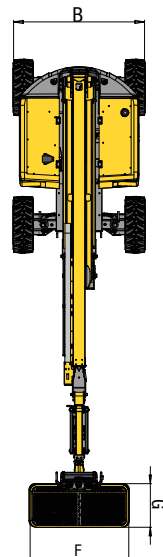
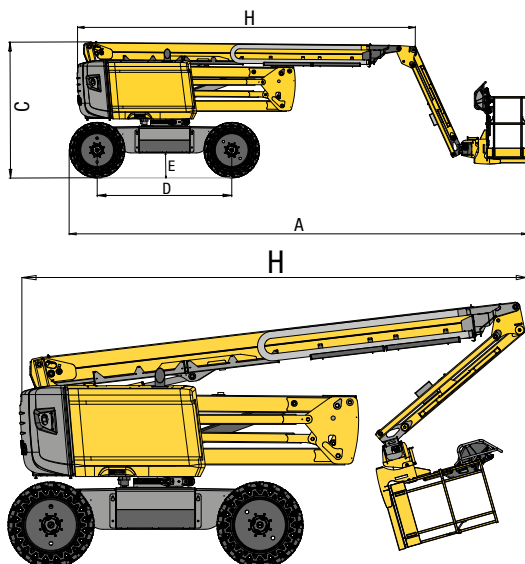

Authorised Reseller : Shakti Equipments Pvt. Ltd.

Block No. 140, Near Vitawa Octroi Naka, Thane Belapur Road, Vitawa, Thane West - 400 605.

Tel: +91 - 22 - 2542 0127 Email: info@shaktiequipments.com